

DXC-4

E1/T1 Grooming Device

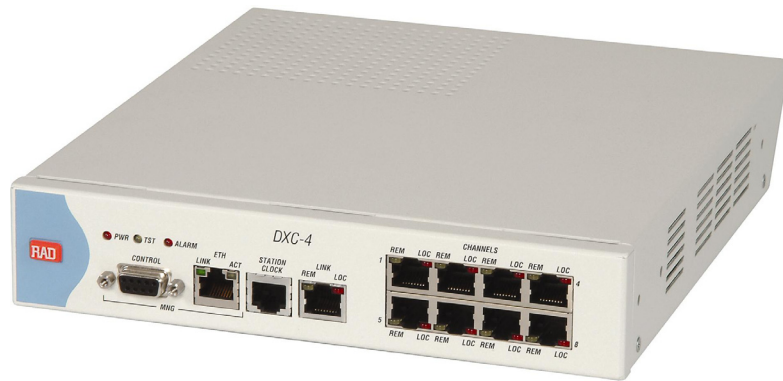

- The E1 interface meets ITU recommendations G.703, G.704, G.706, and G.732. It supports either 2 or 16 frames per multiframe, with or without CRC-4. Line coding is HDB3 or AMI. The user-selectable integral LTU ensures a range of up to 2 km/1.2 miles.
- The T1 interface complies with AT&T TR-62411, ANSI T1.403 and AT&T Pub. 54016. The T1 interface supports D4 and ESF framing formats. Zero suppression over the line is selectable for either transparent, B7ZS or B8ZS. The user-selectable integral CSU ensures a range of up to 2.1 km (1.3 miles).
- Scalable design allows the unit to be ordered with 4 or 8 ports, to support 4 or 8 link channels.

FEATURES

- Standalone unit for grooming E1/T1 digital transmission lines
- Grooms timeslots on up to 8 E1/T1 links over a single E1/T1 uplink
- Improves network performance
- Includes SNMP management:
 - Out-of-band via V.24 or Ethernet supervisory port
 - Inband via dedicated timeslot
- Local and remote loopbacks on the uplink and link channels
- Optional redundant power supply
- Ready for ETSI rack installation

DESCRIPTION

- DXC-4 is a standalone unit used for grooming E1/T1 digital transmission lines. DXC-4 can groom DS0 timeslots including the signaling information, into a single E1/T1 link towards a central location. It can also groom traffic from up to 8 fractional E1/T1 links into a single E1/T1 uplink.
- Status and diagnostic information is defined, configured, and monitored using one of the following methods:
 - Serial connection using a local terminal
 - Ethernet connection using SNMP and RADview, RAD's client-server, or CORBA-based Network Management System
 - Telnet
 - Web browser
 - Inband, using a dedicated timeslot over the E1/T1 uplink (for remote units).

DXC-4

E1/T1 Grooming Device

- The E1 uplink interface is switch-selectable for a 120Ω balanced interface, or 75Ω unbalanced interface. T1 links have a 100Ω balanced interface.
- DXC-4 can operate in the following timing modes:
 - Internal: The internal oscillator of DXC-4 provides clock signals to the E1/T1 uplink and link channels
 - Station: The unit uses a station clock from its station input as the transmit clock for the uplink and link channels. It can also transmit the station clock to another DXC-4 device. The station clock rate is 2.048 Mbps for E1 links and 1.544 Mbps for T1 links.
 - External (LBT): Clocking is taken from one of the received clocks from the uplink or from any of the link channels
 - Automatic: DXC-4 checks the link channels for synchronization and uses the receive clock of the first synchronized channel.
- Diagnostic capabilities include local and remote loopbacks on the E1/T1 uplink and link channels.
- The device has a combined AC/DC power supply with optional redundancy.
- DXC-4 is a compact standalone unit. One or two units can be installed side-by-side in a 19-inch rack using an optional rack mount adapter kit.

APPLICATIONS

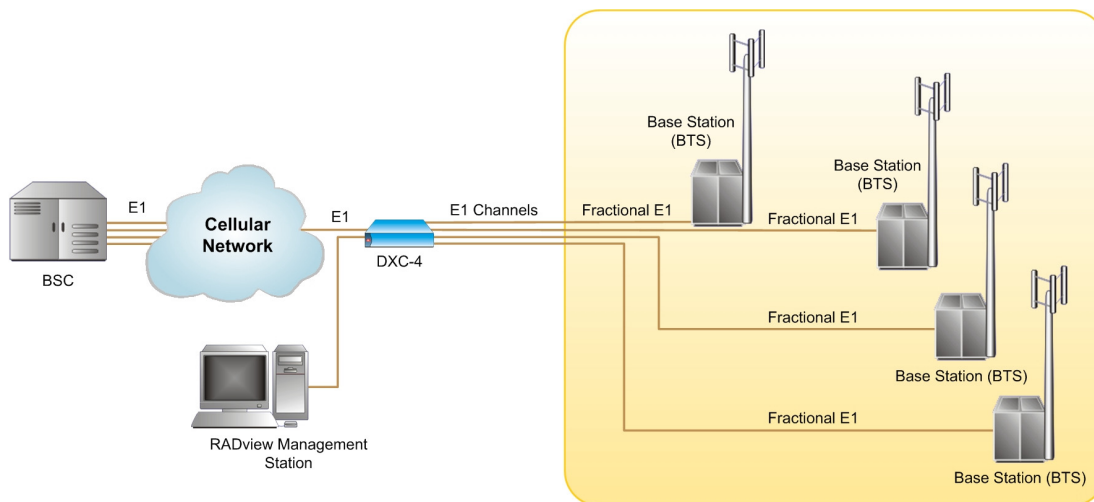

Figure 1. Aggregating Fractional Traffic to E1 Lines

E1/T1 Grooming Device

SPECIFICATIONS

E1 UPLINK AND LINK CHANNELS

- **Number of Uplinks**
1
- **Number of Link Channels**
4 or 8 (see *Ordering*)
- **Framing**
 - G732N, with or without CRC-4
 - G732S, with or without CRC-4
- **Bit Rate**
2.048 Mbps
- **Line Code**
HDB3 or AMI
- **Signal Level**
 - Receive, uplink:
0 to -10 dB, balanced, with DSU
0 to -6 dB, unbalanced, with DSU
0 to -36 dB, balanced, with LTU
 - Receive, link channels:
0 to -15 dB with DSU
0 to -36 dB with LTU
 - Transmit:
±3V (±10%), balanced
±2.37V (±10%), unbalanced
- **Line Impedance**
 - 120Ω, balanced
 - 75Ω, unbalanced
- **Connectors (per port)**
 - Balanced:
RJ-45, 8-pin
 - Unbalanced:
RJ-45 (requires adapter cable CBL-RJ45/2BNC/E1 to convert to a pair of BNC connectors)

- **Timing**
 - Internal accuracy: ±30 ppm
 - Loopback timing: ±130 ppm
 - Station timing: ±130 ppm
- **Compliance**
AT&T TR-62411, AT&T Pub. 54016, ANSI T1.403
- **Jitter Performance**
As per ITU G.823, ETSI TBR-12 and TBR-13
- **Pulse Shape**
Per ITU-T Rec. G.703

T1 UPLINK AND LINK CHANNELS

- **Number of Uplinks**
1
- **Number of Link Channels**
4 or 8 (see *Ordering*)
- **Framing**
 - D4
 - ESF
- **Bit Rate**
1.544 Mbps
- **Line Code**
AMI
- **Zero Suppression**
Transparent, B7ZS, B8ZS
- **Line Impedance**
100Ω, balanced
- **Timing**
Internal accuracy: ±30 ppm
Loopback timing: ±130 ppm
Station timing: ±130 ppm

- **Signal Level**
 - Receive, uplink:
0 to -10 dB without CSU
0 to -36 dB with CSU
 - Receive, link channels:
0 to -15 dB without CSU
0 to -36 dB with CSU
 - Transmit:
0, -7.5, -15, -22.5 dB with CSU
±3V ±10% soft adjustable at
0 to 655 ft without CSU

- **Compliance**
AT&T TR-62411, AT&T Pub. 54016, ANSI T1.403

- **T1 Jitter Performance**
As per AT&T TR-62411

- **Pulse Shape**
Per ITU-T Rec. G.703
- **Connectors (per port)**
RJ-45, 8-pin

STATION CLOCK PORT

- **Format**
Framed / Unframed 1s
G.703 compatible
- **Bit Rate**
E1: 2.048 Mbps
T1: 1.544 Mbps
- **Line Code**
E1: HDB3
T1: B8ZS
- **Connector**
RJ-45, 8-pin

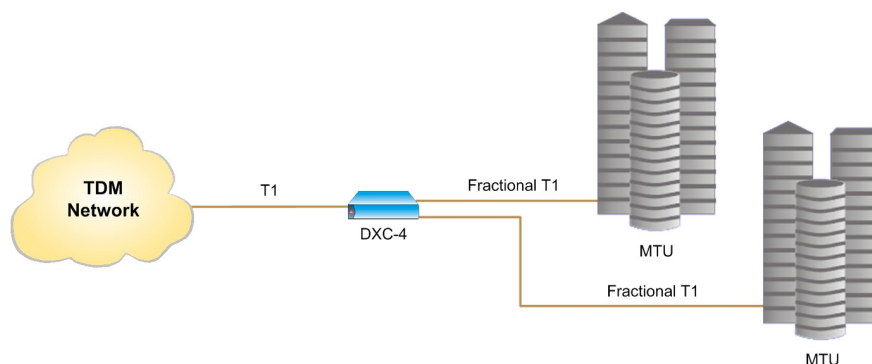

Figure 2. MTU Fractional Service Aggregation

DXC-4

E1/T1 Grooming Device

SUPERVISORY AND MANAGEMENT PORTS

- **V.24/RS-232 CONTROL Port**
Interface: V.24/RS-232
Connector: 9-pin D-type, female
Format: Asynchronous
Baud rate: 9.6 to 115.2 kbps
Character: no parity, odd or even parity
Stop bits: 1, 1.5, or 2
- **ETH Port**
Interface: 10/100BaseT
Connector: RJ-45 shielded

GENERAL

- **Indicators**
General:
 - PWR (green) – On when the power supply is on
 - TST (yellow) – On when a loopback test is active
 - ALARM (red) – On when an alarm enters the alarm bufferE1/T1 Uplink:
 - LOC (red) – On when the local uplink is not synchronized
 - REM (yellow) – On when remote uplink is not synchronizedLink Channels:
 - LOC per channel (red) – On when the local uplink is not synchronized
 - REM per channel (yellow) – On when the remote uplink is not synchronizedETH Management Port:
 - LINK (green) – On when a 10/100BaseT link is established
 - ACT (yellow) – On when activity is present on the management link

- **Timeslot Allocation**
User-defined, any timeslot maps to any other timeslot
- **Diagnostics**
Local and remote loopbacks on the E1/T1 uplink and link channels
- **Power**
Combined AC/DC power supply with redundancy:
100 to 240 VAC, 7VA
–48 VDC, 7W
- **Physical**
Height: 4.4 cm (1.7 in)
Width: 21.5 cm (8.5 in)
Depth: 21.3 cm (8.4 in)
Weight: 0.9 kg (2.0 lb)
- **Environment**
Temperature: 0–50°C
(32–122°F)
Humidity: Up to 90%,
non-condensing

ORDERING

DXC-4/#/&

E1/T1 Grooming Device

- # Specify number of link channels:
4 for 4 E1/T1 ports
8 for 8 E1/T1 ports
- & Specify **R** for redundant power supply

SUPPLIED ACCESSORIES

AC/DC power cord

OPTIONAL ACCESSORIES

RM-35/@

Hardware kit for mounting one or two units in a 19-inch rack

- @ Specify rack mount kit type:
P1 for mounting one unit
P2 for mounting two units



data communications

www.rad.com

- **International Headquarters**
24 Raoul Wallenberg Street
Tel Aviv 69719, Israel
Tel: 972-3-6458181
Fax: 972-3-6498250
Email: market@rad.com
- **North America Headquarters**
900 Corporate Drive
Mahwah, NJ 07430, USA
Tel: (201) 529-1100
Toll free: 1-800 444-7234
Fax: (201) 529-5777
Email: market@radusa.com

379-100-01/06