

ARC-101

ATM Rate and Media Converter



- ARC-101 supports a wide variety of ATM data rates and media types. These include: E1, E3, T3 and STS-3c/STM-1 over optical and electrical interfaces.
- The modular construction and software based design of ARC-101 enables easy migration to new ATM physical interfaces.
- Built-in diagnostics, configuration, statistics (including physical layer alarm surveillance/ performance monitoring) and ATM layer statistics are provided via the monitor connector (RS-232 ASCII terminal).
- ARC-101 is supplied as a standalone unit. Special hardware for mounting one or two units in a 19" rack using minimal height of 1U can be ordered separately (see *Ordering*).

FEATURES

- Modular ATM Rate and Media Converter
- Connects ATM devices with different rates and/or interfaces
- Supports Available Bit Rate (ABR) traffic management for avoiding cell loss
- Transparent to ATM protocols
- Modules available for the following electrical interfaces:
 - 2 Mbps (E1) over coax/UTP
 - 34 Mbps (E3) over coax
 - 45 Mbps (T3) over coax
 - 155 Mbps (STS-3c) over Cat-5 UTP
 - 155 Mbps (STS-3c/STM-1) over coax
- Supports single mode or multimode 155 Mbps STS-3c/STM-1(SONET/SDH) optical interfaces:
- Complies with ATM forum specifications

DESCRIPTION

- ARC-101, ATM rate and media converter, provides transparent rate and media conversion between two ATM interfaces by extracting ATM cells from one interface and sending them over the second one.
- ARC-101 connects devices with dissimilar ATM interfaces. Alternatively, ARC-101 can be used in ATM testing environments, enabling module interchangeability according to the devices being tested.
- A large internal FIFO is used for rate adaptation between the two interfaces and for handling the bursty nature of the ATM traffic. Special circuitry is responsible for closing the ATM flow control loop according to ABR traffic management specifications in order to avoid FIFO overflow

ARC-101

ATM Rate and Media Converter

SPECIFICATIONS

- **Data Rate**
Up to 155 Mbps

GENERAL

- **Indicators**
 - PWR ON when unit is powered
 - FLT BLINKS when self-test fails
 - ATM ON when active ATM connections on port
 - SYNC ON when the port is synchronized (no alarm)
OFF during local alarm
BLINKS during remote alarm

All indicators are green, except FLT which is red.

- **Control Interface**
RS-232/V.24 at 9600 baud with RJ-45 connector
- **Power**
100–230V AC, 47–63 Hz or -48V DC
Consumption: 25W
- **Physical**
Height: 4.4 cm / 1.8 in
Width: 21.6 cm / 8.5 in
Depth: 29.8 cm / 11.7 in
Weight 1.1 kg / 2.8 lb
- **Environment**
Temperature: 0–45°C/32–113°F
Humidity: Up to 90%, non-condensing

ORDERING

ARC-101/#

ATM Rate and Media Converter

ARC-M/@

Interface module for ARC-101

Specify power supply:
AC for 100–230V AC
DC for -48V DC

@ Specify module name:
(refer to tables 1 and 2)

RM-21

Hardware for mounting two units in a 19" rack

Table 1. Optical Modules Characteristics

Module Name	Protocols Supported	Fiber Type (Wavelength)	Connector Type	Dynamic Range	Optical Power	Sensitivity
SC13M/155	STS-3c/STM-1	1300 nm, (multimode)	Duplex SC	17 dB	-18 dBm	-31 dBm
ST13S/155	STS-3c/STM-1	1300 nm, (single mode)	ST	16 dB	-18 dBm	-31 dBm
ST13L/155	STS-3c/STM-1	1300 nm, (laser diode)	ST	16 dB	-12 dBm	-31 dBm

Table 2. Electrical Modules Characteristics

Module Name	Protocols Supported	Cable Type	Connector Type	Range/Budget	Line Code	Impedance (Ω)
UTP/155	STS-3c/STM-1	UTP Cat 5	Shielded RJ-45	100 m	NRZ	100
CX/155	STS-3c/STM-1	coax	BNC	12.7 dB	CMI	75
T3	T3	coax	BNC	150 m	B3ZS	75
E3	E3	coax	BNC	150 m	HDB3	75
E1	E1	coax (UTP)	BNC (RJ-45)	12 dB	HDB3	75 (120)
E1/LTU	E1	coax (UTP)	BNC (RJ-45)	34 dB	HDB3	75 (120)

APPLICATION

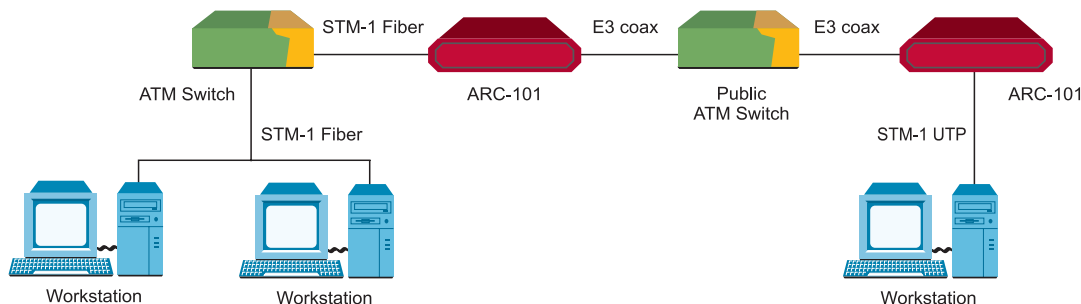

RAD

data communications

www.rad.com

- **International Headquarters**
24 Raoul Wallenberg Street
Tel Aviv 69719, Israel
Tel: (972) 3-6458181
Fax: (972) 3-6498250, 6474436
Email: rad@rad.co.il

- **U.S. Headquarters**
900 Corporate Drive
Mahwah, NJ 07430
Tel: (201) 529-1100
Toll free: 1-800-444-7234
Fax: (201) 529-5777
Email: market@radusa.com

334-100-08/00