



NetVanta 950 IAD Hardware Installation Guide

1200785L1	NetVanta 950 IAD AC Power Supply
1200786L1	NetVanta 950 IAD AC Chassis
1200788L1	NetVanta 950 IAD System Controller
1200791L1	NetVanta 950 IAD Octal FXS Module
1200793L1	NetVanta 950 IAD Ethernet Switch Module
1200798L1	NetVanta 950 IAD T1/V.35 Expansion Module

Trademarks

Any brand names and product names included in this manual are trademarks, registered trademarks, or trade names of their respective holders.

To the Holder of this Manual

The contents of this manual are current as of the date of publication. ADTRAN reserves the right to change the contents without prior notice.

In no event will ADTRAN be liable for any special, incidental, or consequential damages or for commercial losses even if ADTRAN has been advised thereof as a result of issue of this publication.



901 Explorer Boulevard
P.O. Box 140000
Huntsville, AL 35814-4000
Phone: (256) 963-8000
www.adtran.com

©2004 ADTRAN, Inc.
All Rights Reserved.
Printed in U.S.A.

Conventions

**NOTE**

Notes provide additional useful information.

**CAUTION**

Cautions signify information that could prevent service interruption.

WARNING

Warnings provide information that could prevent damage to the equipment or endangerment to human life.

Safety Instructions

When using your communications equipment, please follow these basic safety precautions to reduce the risk of fire, electrical shock, or personal injury:

1. Do not use this product near water such as a bathtub, wash bowl, kitchen sink, laundry tub, in a wet basement, or near a swimming pool.
2. Avoid using a telephone (other than a cordless-type) during an electrical storm. There is a remote risk of shock from lightning.
3. Do not use a telephone to report a gas leak in the vicinity of the leak.
4. Use only the power cord, power supply, and/or batteries indicated in the manual. Do not dispose of batteries in a fire. They may explode. Check with local codes for special disposal instructions.

Save These Important Safety Instructions

Affidavit Requirements for Connection to Digital Services

- An affidavit is required to be given to the telephone company whenever digital terminal equipment (DTE) without encoded analog content and billing protection is used to transmit digital signals containing encoded analog content intended for eventual conversion into voiceband analog signals and transmitted on the network.
- The affidavit shall affirm that either no encoded analog content or billing information is being transmitted or that the output of the device meets Part 68 encoded analog content or billing protection specifications.
- The end user/customer will be responsible for filing an affidavit with the local exchange carrier when connecting unprotected customer premise equipment (CPE) to 1.544 Mbps or subrate digital services.
- Until such time as subrate DTE is registered for voice applications, the affidavit requirement for subrate services is waived.

**Affidavit for Connection of Customer Premises Equipment
to 1.544 Mbps and/or Subrate Digital Services**

For the work to be performed in the certified territory of _____ (telco name)

State of _____

County of _____

I, _____ (name), _____ (business address),

_____ (telephone number) being duly sworn, state:

I have responsibility for the operation and maintenance of the terminal equipment to be connected to 1.544 Mbps and/or _____ subrate digital services. The terminal equipment to be connected complies with Part 68 of the FCC rules except for the encoded analog content and billing protection specifications. With respect to encoded analog content and billing protection:

- () I attest that all operations associated with the establishment, maintenance, and adjustment of the digital CPE with respect to analog content and encoded billing protection information continuously complies with Part 68 of the FCC Rules and Regulations.
- () The digital CPE does not transmit digital signals containing encoded analog content or billing information which is intended to be decoded within the telecommunications network.
- () The encoded analog content and billing protection is factory set and is not under the control of the customer.

I attest that the operator(s)/maintainer(s) of the digital CPE responsible for the establishment, maintenance, and adjustment of the encoded analog content and billing information has (have) been trained to perform these functions by successfully having completed one of the following (check appropriate statements):

- () A. A training course provided by the manufacturer/grantee of the equipment used to encode analog signals; or
- () B. A training course provided by the customer or authorized representative, using training materials and instructions provided by the manufacturer/grantee of the equipment used to encode analog signals; or
- () C. An independent training course (e.g., trade school or technical institution) recognized by the manufacturer/grantee of the equipment used to encode analog signals; or
- () D. In lieu of the preceding training requirements, the operator(s)/maintainer(s) is (are) under the control of a supervisor trained in accordance with _____ (circle one) above.

I agree to provide _____ (telco's name) with proper documentation to demonstrate compliance with the information as provided in the preceding paragraph, if so requested.

Signature

Title

Date

Transcribed and sworn to before me

This _____ day of _____, _____

Notary Public

My commission expires:

FCC regulations require that the following information be provided in this manual:

1. This equipment complies with Part 68 of FCC rules and requirements adopted by ACTA. Each registered interface has a label that contains, among other information, a product identifier in the format US:AAAEQ##TXXXX. If requested, provide this information to the telephone company.
2. If this equipment causes harm to the telephone network, the telephone company may temporarily discontinue service. If possible, advance notification is given; otherwise, notification is given as soon as possible. The telephone company will advise the customer of the right to file a complaint with the FCC.
3. The telephone company may make changes in its facilities, equipment, operations, or procedures that could effect the proper operation of this equipment. Advance notification and the opportunity to maintain uninterrupted service are given.
4. If experiencing difficulty with this equipment, please contact ADTRAN for repair and warranty information. The telephone company may require this equipment to be disconnected from the network until the problem is corrected or it is certain the equipment is not malfunctioning.
5. This unit contains no user-serviceable parts.
6. This equipment is designed to connect to the telephone network or premises wiring using an FCC-compatible modular jack, which is compliant with Part 68 and requirements adopted by ACTA.
7. The following information may be required when applying to the local telephone company for leased line facilities:

Part Number	Registration Number	Service Type	REN/SOC	FIC	USOC
1200786L1	US: HDCDFNAN1200788L1	1.544 Mbps - SF 1.544 Mbps - SF and B8ZS	6.0N	04DU9-BN 04DU9-DN	RJ-48C
1200798L1	US: HDCDENAN1200798L1	1.544 Mbps - ESF 1.544 Mbps - ESF and B8ZS		04DU9-1KN 04DU9-1SN	

8. The REN is useful in determining the quantity of devices you may connect to your telephone line and still have all of those devices ring when your number is called. In most areas, the sum of the RENs of all devices should not exceed five. To be certain of the number of devices you may connect to your line as determined by the REN, call your telephone company to determine the maximum REN for your calling area.
9. This equipment may not be used on coin service provided by the telephone company. Connection to party lines is subject to state tariffs. Contact your state public utility commission or corporation commission for information.

Federal Communications Commission Radio Frequency Interference Statement

This equipment has been tested and found to comply with the limits for a Class A digital device, pursuant to Part 15 of the FCC Rules. These limits are designed to provide reasonable protection against harmful interference when the equipment is operated in a commercial environment. This equipment generates, uses, and can radiate radio frequency energy and, if not installed and used in accordance with the instruction manual, may cause harmful interference to radio frequencies. Operation of this equipment in a residential area is likely to cause harmful interference in which case the user will be required to correct the interference at his own expense.

WARNING

Changes or modifications to this unit not expressly approved by the party responsible for compliance could void the user's authority to operate the equipment.

Industry Canada Compliance Information

Notice: The Industry Canada label applied to the product (identified by the Industry Canada logo or the “IC:” in front of the certification/registration number) signifies that the Industry Canada technical specifications were met.

Notice: The Ringer Equivalence Number (REN) for this terminal equipment is supplied in the documentation or on the product labeling/markings. The REN assigned to each terminal device indicates the maximum number of terminals that can be connected to a telephone interface. The termination on an interface may consist of any combination of devices subject only to the requirement that the sum of the RENs of all the devices should not exceed five (5).

Canadian Emissions Requirements

This digital apparatus does not exceed the Class A limits for radio noise emissions from digital apparatus as set out in the interference-causing equipment standard entitled “Digital Apparatus,” ICES-003 of the Department of Communications.

Cet appareil numérique respecte les limites de bruits radioélectriques applicables aux appareils numériques de Class A prescrites dans la norme sur le matériel brouilleur: “Appareils Numériques,” NMB-003 édictée par le ministre des Communications.

Product Warranty

ADTRAN will repair and return this product within the warranty period if it does not meet its published specifications or fails while in service. Warranty information can be found at www.adtran.com/warranty.

Product Registration

Registering your product helps ensure complete customer satisfaction. Please take time to register your products on line at www.adtran.com. Click *Service and Support* on the top of the page, and then click *Product Registration* under *Support*.

Customer Service, Product Support Information, and Training

ADTRAN will repair or return this product within the warranty period if it does not meet its published specifications or fails while in service. Warranty information can be found at www.adtran.com/warranty.

A return material authorization (RMA) is required prior to returning equipment to ADTRAN. For service, RMA requests, training, or more information, use the contact information given below.

Repair and Return

If you determine that a repair is needed, please contact our Customer and Product Service (CaPS) department to have an RMA number issued. CaPS should also be contacted to obtain information regarding equipment currently in house or possible fees associated with repair.

CaPS Department (256) 963-8722

Identify the RMA number clearly on the package (below address), and return to the following address:

ADTRAN Customer and Product Service
901 Explorer Blvd. (East Tower)
Huntsville, Alabama 35806

RMA # _____

Pre-Sales Inquiries and Applications Support

Your reseller should serve as the first point of contact for support. If additional pre-sales support is needed, the ADTRAN Support web site provides a variety of support services such as a searchable knowledge base, latest product documentation, application briefs, case studies, and a link to submit a question to an Applications Engineer. All of this, and more, is available at:

<http://support.adtran.com>

When needed, further pre-sales assistance is available by calling our Applications Engineering Department.

Applications Engineering (800) 615-1176

Post-Sale Support

Your reseller should serve as the first point of contact for support. If additional support is needed, the ADTRAN Support web site provides a variety of support services such as a searchable knowledge base, updated firmware releases, latest product documentation, service request ticket generation and trouble-shooting tools. All of this, and more, is available at:

<http://support.adtran.com>

When needed, further post-sales assistance is available by calling our Technical Support Center. Please have your unit serial number available when you call.

Technical Support (888) 4ADTRAN

Installation and Maintenance Support

The ADTRAN Custom Extended Services (ACES) program offers multiple types and levels of installation and maintenance services which allow you to choose the kind of assistance you need. This support is available at:

<http://www.adtran.com/aces>

For questions, call the ACES Help Desk.

ACES Help Desk (888) 874-ACES (2237)

Training

The Enterprise Network (EN) Technical Training Department offers training on our most popular products. These courses include overviews on product features and functions while covering applications of ADTRAN's product lines. ADTRAN provides a variety of training options, including customized training and courses taught at our facilities or at your site. For more information about training, please contact your Territory Manager or the Enterprise Training Coordinator.

Training Phone (800) 615-1176, ext. 7500

Training Fax (256) 963-6700

Training Email training@adtran.com

TABLE OF CONTENTS

1. Introduction to the NetVanta 950 IAD Solution	15
Features and Specifications	15
Unpack and Inspect the System	16
Contents of ADTRAN Shipments	16
2. Product Overview	17
Reviewing the Chassis Front Panel Designs	17
Front Panel LEDs	18
Reviewing the Chassis Panel Design	18
Side Panel Interfaces	20
3. Modules	22
NetVanta 950 IAD Controller (P/N 1200788L1)	23
NetVanta 950 IAD T1/V.35 Expansion Module (P/N 1200798L1)	24
NetVanta 950 IAD Octal FXS Access Module (P/N 1200791L1)	25
NetVanta 950 IAD Octal Ethernet Switch Access Module (P/N 1200793L1).....	26
4. Unit Installation	27
Tools Required	27
Mounting Options	28
Wallmounting NetVanta 950 IAD	28
Rackmounting NetVanta 950 IAD	29
Installing Modules	30
Grounding Instructions	30
Grounding for AC Power	31
Grounding for DC Power (Optional Battery Backup)	31
Supplying Power to the Unit	31
5. Battery Backup Unit	32
Features	32
Unpack and Inspect	32
Safety Notices	33
Installation of the Battery Pack	33
Wallmount Installation	34
Maintenance	35
Specifications	35
Chassis Pinouts	37
Controller Pinouts	37
Module Pinouts	38

Figures

Figure 1. NetVanta 950 IAD Front Panel Layout	17
Figure 2. NetVanta 950 IAD Right Side Panel Layout	19
Figure 3. NetVanta 950 IAD Left Side Panel Layout	19
Figure 4. Voice Connector Pin Assignment	21
Figure 5. NetVanta 950 IAD Controller Module	23
Figure 6. NetVanta 950 IAD T1/V.35 Expansion Module	24
Figure 7. NetVanta 950 IAD Octal FXS Access Module	25
Figure 8. NetVanta 950 IAD Ethernet Switch Access Module	26
Figure 9. Wallmounting the NetVanta 950 IAD	28
Figure 10. Rackmounting the NetVanta 950 IAD	29
Figure 11. NetVanta 950 IAD Battery Pack Connections	33
Figure 12. Battery Pack Mounting Dimensions	34

Tables

Table 1. NetVanta 950 IAD LEDs.....	18
Table 2. Battery Pack Specifications	35
Table A-1. WAN 0/1, 0/2 Connector Pinout	37
Table A-2. Alarm Contacts	37
Table A-3. 10/100BaseT Ethernet Port Pinout	37
Table A-4. Console Port (DCE) Pinout	38
Table A-5. T1 Connector Pinout.....	38
Table A-6. V.35 Connector Pinout	39
Table A-7. 10/100BaseT Ethernet Port Pinout	39
Table A-8. Voice Interface Pinout (Slots 2 - 4).....	40
Table A-9. Voice Interface Pinout (Slots 5 - 7).....	41
Table B-1. MIBs Supported in the AOS.....	43
Table B-2. Notes Regarding MIB Exclusions	44
Table B-3. Traps Supported in the AOS.....	46

1. INTRODUCTION TO THE NETVANTA 950 IAD SOLUTION

The NetVanta 950 IAD is a modular integrated access device that incorporates dual T1 network access, a variety of modules to customize the solution, and an integral router using the ADTRAN Operating System (ADTRAN OS).

The NetVanta 950 IAD family includes the NetVanta 950 IAD AC Chassis, AC power supply, system controller, and various modules for voice and data applications. Currently, the NetVanta 950 IAD family offers an Octal FXS Module for voice applications, a T1/V.35 Expansion Module for data applications, and an Octal Ethernet Switch Module for local area network needs.

Features and Specifications

The NetVanta 950 IAD has the following features:

- Dual T1 network access located on the side of the chassis (RJ-45)
- Integrated 10/100BaseT Ethernet port (RJ-48C)
- Integrated IP router with bridging
- ADTRAN Operating System Command Line Interface (CLI)
- SNMP management
- Integrated EIA-232 DCE configuration port located on the system controller module (DB-9)
- LEDs for module status information
- Chassis dimensions: 7.5"H x 10"W x 7"D
- AC power information: 120 VAC, 60 Hz

This hardware installation guide describes the NetVanta 950 IAD units, details basic functionality, gives installation instructions, and lists unit specifications. For more information on a specific application, refer to the quick start documents provided on your ADTRAN OS System Documentation CD. For details on the command line interface, refer to the *AOS Command Reference Guide* (also included on your CD).

WARNING

The NetVanta 950 IAD system is intended to be installed, maintained, and serviced by qualified personnel only.

Unpack and Inspect the System

Each NetVanta 950 IAD unit is shipped in its own cardboard shipping carton. Open the carton carefully and avoid deep penetration into the carton with sharp objects.

After unpacking the unit, inspect it for possible shipping damage. If the equipment has been damaged in transit, immediately file a claim with the carrier and contact ADTRAN Customer Service (see *Product Warranty*, on page 10).

Contents of ADTRAN Shipments

NetVanta 950 IAD AC System

Shipments of the NetVanta 950 IAD include the following items:

- NetVanta 950 IAD AC Chassis/Power Supply/Controller
- CD documentation, Quick Start Guide, and Wallmount Guide
- Warranty Card
- IEC 3-prong power cord
- Two 15' RJ-45 cables (3125M008@A)
- Four #8 lug screws for wallmounting

NetVanta 950 IAD T1/V.35 Expansion Module

Shipments of the T1/V.35 Expansion Module include the following items:

- T1/V.35 Expansion Module
- Quick Start Guide
- 15' straight RJ cable (3125M008@A)
- 15' crossover RJ-45 cable (3125M010@A)

NetVanta 950 IAD Octal FXS Access Module

Shipments of the Octal FXS Access Module include the following items:

- Octal FXS Access Module
- Quick Start Guide

NetVanta 950 IAD Octal Ethernet Switch Access Module

Shipments of the Octal Ethernet Switch Access Module include the following items:

- Octal Ethernet Switch Access Module
- Quick Start Guide

WARNING

Modules are intended to be serviced by qualified service personnel only.

2. PRODUCT OVERVIEW

Reviewing the Chassis Front Panel Designs

Figure 1 shows the NetVanta 950 IAD front panel.

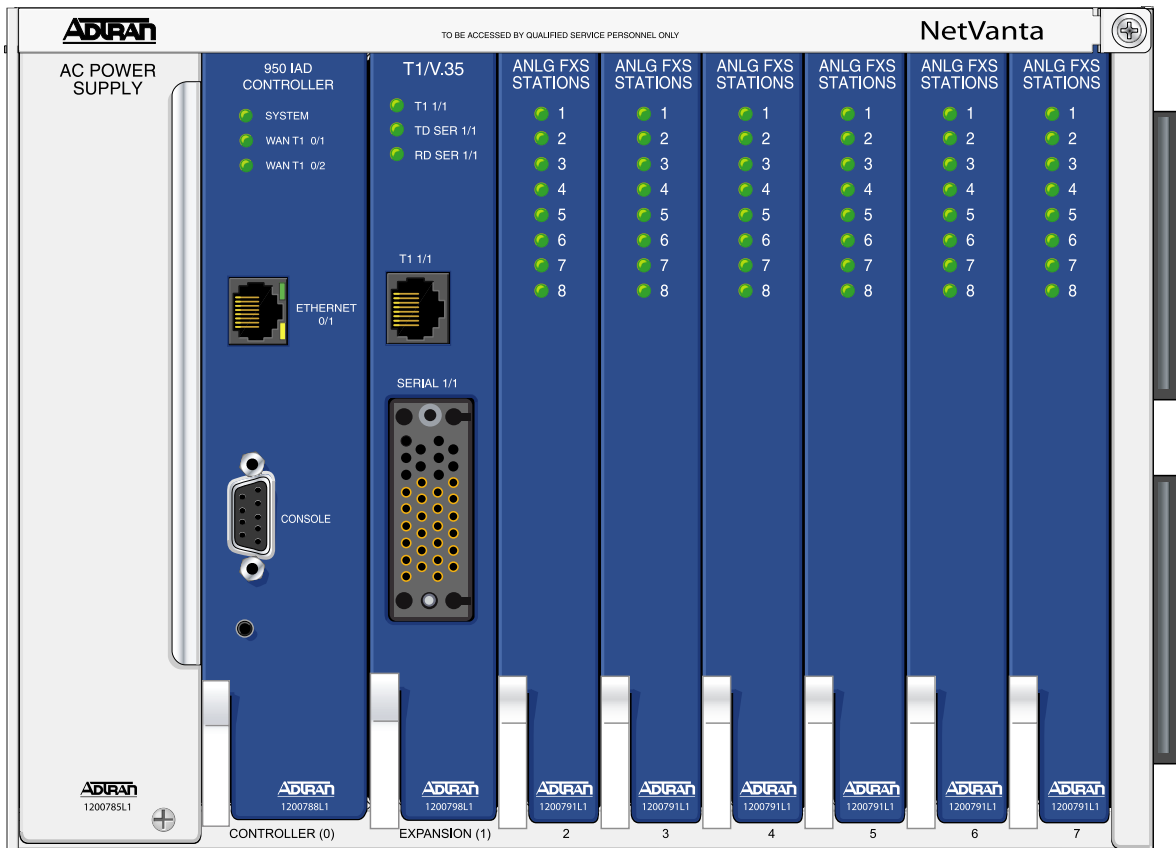

Figure 1. NetVanta 950 IAD Front Panel Layout

Front Panel LEDs

Table 1 describes the controller card LEDs in order as located from top to bottom.

Reviewing the Chassis Panel Design

Table 1. NetVanta 950 IAD LEDs

For these LEDs...	This activity...	Indicates that...
System	Off	No power to the unit.
	Green (solid)	The power is on and self-test passed.
	Red (solid)	The self-test failed or the boot mode (if applicable) code could not be booted. It may also mean battery power is being used.
WAN (1 and 2)	Off	The WAN interface is administratively down.
	Green (solid)	The link is up and everything is normal.
	Red (solid)	An alarm condition is occurring on the WAN interface, or there is a self-test failure.
	Yellow (solid)	The interface unit is in test.
Ethernet	Green (off)	The link is down.
	Green (solid)	The link is up.
	Amber (off)	No traffic on the link.
	Amber (blink)	Blinks with traffic on the interface.

Figure 2 and Figure 3 on page 19 show the NetVanta 950 IAD side panels. All voice connections are provided through two 50-pin amphenol connectors (located on the right side panel). The left side panel contains the battery backup connector, the T1 network connections, the alarm contacts, the power connection, and the ground lug.

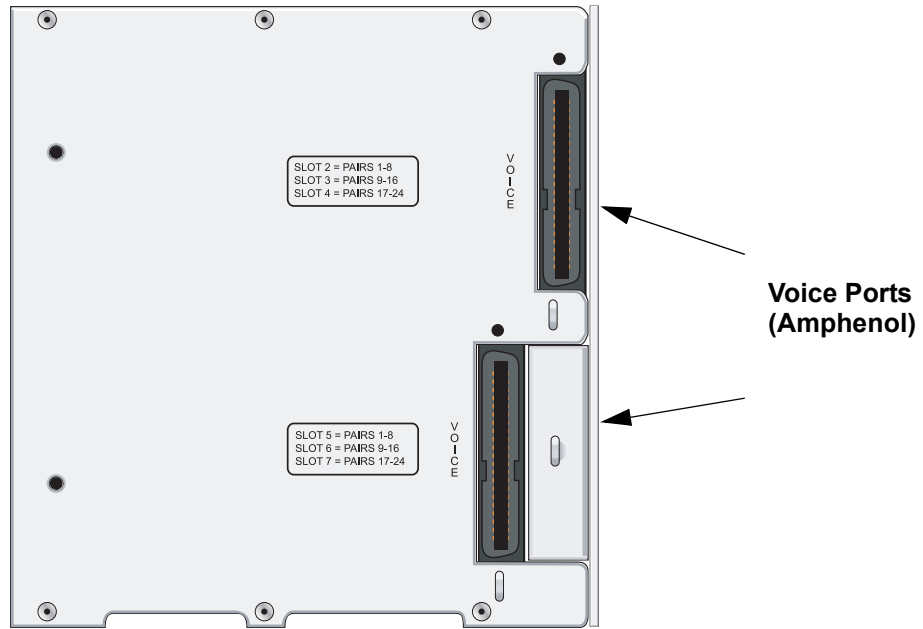

Figure 2. NetVanta 950 IAD Right Side Panel Layout

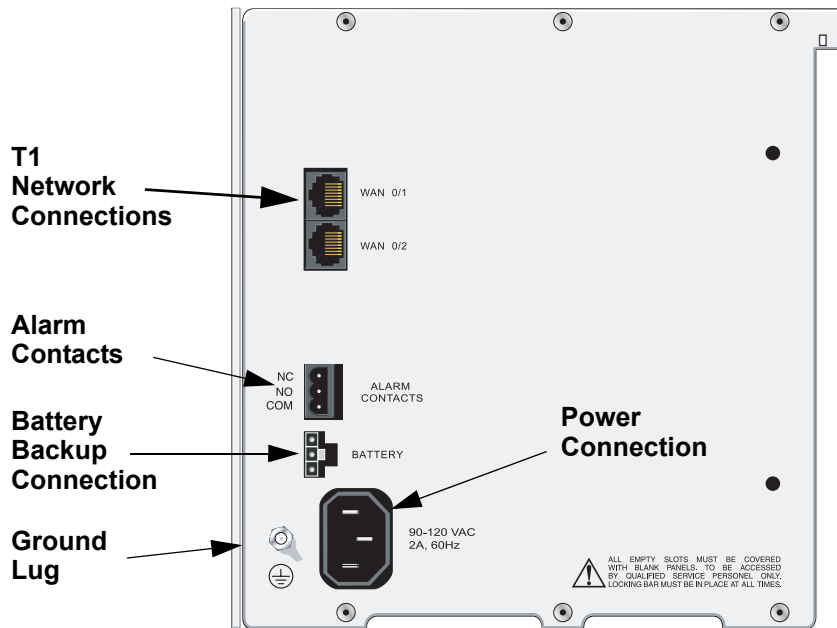

Figure 3. NetVanta 950 IAD Left Side Panel Layout

Side Panel Interfaces

WAN Interfaces

The NetVanta 950 IAD provides two RJ-48C connectors on the left side panel for connection to T1 network services. Status LEDs for the WAN interfaces are integrated on the Controller (see page 18 for more details on the LEDs). See Table A-1 on page 37 for the WAN interface pinout. The WAN interface provides the following:

- AMI or B8ZS coding
- Manual line build-out
- D4 or ESF framing
- Test loopbacks with QRSS generation and checking (through the Controller)

Alarm Contacts

This connection alerts the user when an alarm condition exists. The 3-pin, removable terminal block connects with external wiring. The user should determine whether the external alarm reporting device uses a normally open (NO) or normally closed (NC) circuit for the alarm.

During an alarm condition, the internal alarm relay shorts NO and COM (the relay is closed) and NC is open circuited. Alarm conditions include: Power Failure, Battery Backup (requires optional battery backup), and T1 alarm.

See Table A-2 on page 37 for the Alarm Contact pinout.

Battery Backup Connection

The NetVanta 950 IAD provides a modular plug for connecting to an alternate -48 VDC power supply (ADTRAN power supply/battery charging unit P/N 1175044L1). Refer to the *Battery Backup Unit* on page 32 for more details on this connection.

Voice Connections

The NetVanta 950 IAD provides two 50-pin amphenol connectors for up to 48 tip and ring pairs. Voice modules installed in slots 2 through 4 are available through the top amphenol connector, and slots 5 through 7 use the bottom amphenol connector. An optional 50-port breakout panel is available (P/N 1200799L48 or 1200799L50). For instructions on mounting the breakout panels, refer to the *Breakout Panel Quick Start Guide*, 61200799L48-13A. Figure 4 on page 21 and Table A-9 on page 41 show the Voice Connection pinout.

Top Amphenol Connector

Bottom Amphenol Connector

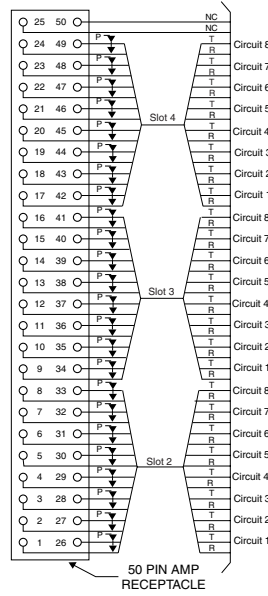

Slots 2-4

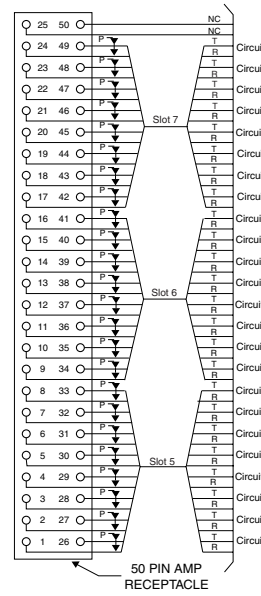

Slots 5-7

Figure 4. Voice Connector Pin Assignment

3. MODULES

The NetVanta 950 IAD series offers several modules designed to meet a variety of networking requirements. The modules are of three types: controller, expansion modules, and access modules.

The following modules are available for the NetVanta 950 IAD:

- NetVanta 950 IAD Controller (see page 23)
- NetVanta 950 IAD T1/V.35 Expansion Module (see page 24)
- NetVanta 950 IAD Octal FXS Access Module (see page 25)
- NetVanta 950 IAD Octal Ethernet Switch Access Module (see page 26)

This section describes each module, providing individual card specifications and features. Refer to *Pin Assignments* on page 37 for pinout information. *Installing Modules* on page 30 provides information on module installation.

WARNING

The NetVanta 950 IAD system is intended to be installed, maintained, and serviced by qualified personnel only.

NetVanta 950 IAD Controller (P/N 1200788L1)

The NetVanta 950 IAD uses a central controller card to provide configuration for the system using the ADTRAN Operating System (AOS). The NetVanta 950 IAD Controller (shown in Figure 5) provides control interfaces for the NetVanta 950 IAD system including a Console port (DB-9) and an Ethernet interface (RJ-48C). Refer to Table A-4 on page 38 for the Console connector pinout, and Table A-3 on page 37 for the Ethernet connector pinout. A Controller module is required for all NetVanta 950 IAD systems.

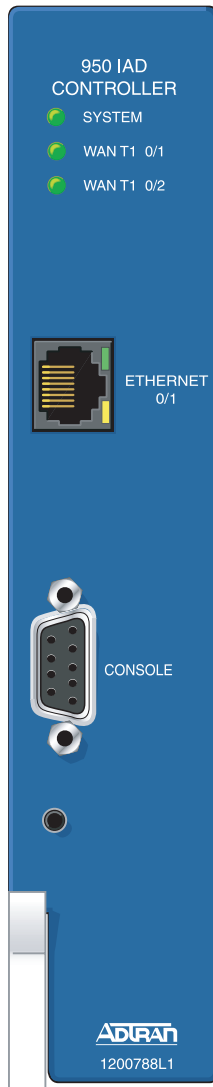

Features and Specifications

Interfaces

- **Console:** EIA-232 (DB-9 female) for access to command line interface and monitoring
- **Ethernet:** 10/100BaseT interface (RJ-48C) for connection to the local area network

Agency Approvals

- FCC Part 15, Class A
- FCC Part 68
- UL 60950, Third Edition/CSA C22.2, No. 60950
- Industry Canada CS-03

Environmental

- Operating Temperature: 0°C to 50°C
- Storage Temperature: -20°C to 70°C
- Relative Humidity: 95% noncondensing

Figure 5. NetVanta 950 IAD Controller Module

NetVanta 950 IAD T1/V.35 Expansion Module (P/N 1200798L1)

The NetVanta 950 IAD T1/V.35 Expansion Module (shown in Figure 6) provides a T1 interface and a V.35 serial interface for the NetVanta 950 IAD. The T1 connection provides a full T1 or fractional T1 interface. The V.35 interface provides a connection to local data equipment. Refer to Table A-5 on page 38 for the T1 connector pinout, and Table A-6 on page 39 for the V.35 connector pinout. Expansion modules are only valid in the NetVanta 950 IAD system expansion slot. The T1/V.35 module may only be installed in Expansion Slot (Slot 1).



Features and Specifications

Interfaces

- **T1:** RJ-48C
- **V.35:** Winchester V.35 (female)

T1 Interface

- Line Rate: 1.544 Mbps +/- 75 bps
- Line Code: AMI or B8ZS
- Framing: D4 (SF) or ESF
- Line Build-Out: 0, -7.5, -15, -22.5 dB

V.35 Interface

- Data Rate: 56K to 1.536 Mbps
- Testing: 511 Pattern

Agency Approvals

- FCC Part 15, Class A
- FCC Part 68
- UL 60950, Third Edition/CSA C.22.2, No. 60950
- Industry Canada CS-03

Environmental

- Operating Temperature: 0°C to 50°C
- Storage Temperature: -20°C to 70°C
- Relative Humidity: 95% non-condensing

Figure 6. NetVanta 950 IAD T1/V.35 Expansion Module

NetVanta 950 IAD Octal FXS Access Module (P/N 1200791L1)

The NetVanta 950 IAD Octal FXS Module (shown in Figure 7) provides eight voice interfaces for the NetVanta 950 IAD system. Refer to Table A-8 on page 40 and Table A-9 on page 41 for the FXS connector pinout. The NetVanta 950 IAD system can use up to six Octal FXS Modules simultaneously.



Features and Specifications

Signaling

- FXS (Foreign Exchange Station) Loop Start (LS), Ground Start (GS)

Transmission Level

- Transmit: -12 dB to +6 dB Gain in 0.1 dB steps
- Receive: -12 dB to +6 dB Gain in 0.1 dB steps

Impedance

- 600Ω, 600Ω +2.16 μF, 900Ω, 900Ω +2.16 μF

Loop Statistics

- Current: 24 mA nominal
- Range: 2400 ft intra-building

Ringling

- 5 REN/port (35 REN maximum for system)
- 70 VRMS with 20V DC offset - open circuit, no load
- Balanced, internal, sinusoidal ring generation

On-hook Battery

- -48V nominal

Port Tests

- 1 kHz test tone (near-end, far-end selectable)
- Loopbacks (analog, digital)
- Ringling, reverse battery, battery, tip open
- Transmit on-hook to network, transmit off-hook to network

Agency Approvals

- FCC Part 15, Class A
- FCC Part 68
- UL 60950, Third Edition/CSA C22.2, No. 60950
- Industry Canada CS-03

Environmental

- Operating Temperature: 0°C to 50°C
- Storage Temperature: -20°C to 70°C
- Relative Humidity: 95% non-condensing

Figure 7. NetVanta 950 IAD Octal FXS Access Module

NetVanta 950 IAD Octal Ethernet Switch Access Module (P/N 1200793L1)

The Ethernet Switch Module (shown in Figure 8) provides eight 10BaseT/100BaseTX (RJ-48C) interfaces for connection to local area networks (LANs). Each interface auto-negotiation and provides auto MDI/MDIX crossover. Refer to Table A-7 on page 39 for the ethernet connector pinout.

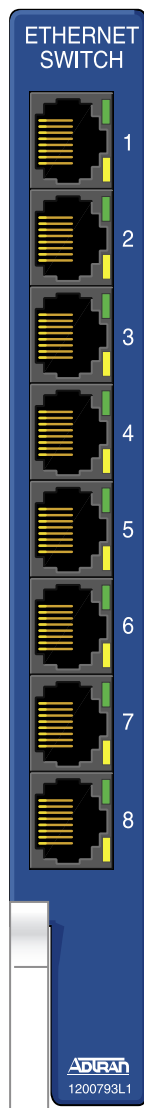

Features and Specifications

Interfaces

- (8) 10BaseT/100BaseTX interfaces supporting auto-negotiation and auto MDI/MDIX crossover

Note: Auto-negotiation must be enabled on a specific port to allow auto MDI/MDIX crossover to function on that port.

- Maximum of 41 LAN interfaces with Ethernet Switch Modules installed in Slots 2 through 6 of the chassis
- The Ethernet Switch Module acts as a stand-alone switch if installed in Slot 7 of the chassis.

Flow Control

- Back-pressure flow control on all half-duplex interfaces
- Pause-frame flow control on full-duplex interfaces

Agency Approvals

- FCC Part 15, Class A
- UL 60950, Third Edition/CS C22.2, No. 60950

Environmental

- Operating Temperature: 0°C to 50°C
- Storage Temperature: -20°C to 70°C
- Relative Humidity: 95% noncondensing

Figure 8. NetVanta 950 IAD Ethernet Switch Access Module

4. UNIT INSTALLATION

The installation, maintenance and service of the NetVanta 950 IAD system is intended to be carried out by qualified personnel only. The instructions and guidelines provided in this section cover hardware installation topics such as wallmounting/rackmounting the unit and installing modules. These instructions are presented as follows:

- *Mounting Options* on page 28
- *Wallmounting NetVanta 950 IAD* on page 28
- *Rackmounting NetVanta 950 IAD* on page 29
- *Installing Modules* on page 30
- *Battery Backup Unit* on page 32

For information on configuring a specific application, refer to the quick start documents provided on your ADTRAN OS System Documentation CD. For details on the command line interface, refer to the *AOS Command Reference Guide* (also included on your CD).

WARNING

To prevent electrical shock, do not install equipment in a wet location or during a lightning storm.

WARNING

The NetVanta 950 IAD system is intended to be installed, maintained, and serviced by qualified personnel only.

Tools Required

The customer-provided tools required for the hardware installation of the NetVanta 950 IAD are:

- Ethernet cable
- Phillips-head screwdriver
- Drill (optional-wallmounting only)
- Flat-head screwdriver (optional - wallmounting only)

NOTE

To access the command line interface (CLI) of the NetVanta 950 IAD, you will also need a VT100 terminal or PC with terminal emulation software and a console port cable. Instructions on how to access the CLI are given in the AOS Command Reference Guide (provided on the ADTRAN OS System Documentation CD).

Mounting Options

The NetVanta 950 IAD may be installed in a wallmount, or rackmount configuration. The following sections provide step-by-step instructions for rackmounting and wallmounting.

Wallmounting NetVanta 950 IAD

NetVanta 950 IAD

Instructions for Wallmounting NetVanta 950 IAD	
Step	Action
1.	Decide on a location for the NetVanta 950 IAD. Keep in mind that the unit needs to be mounted at or below eye-level so that the LEDs are viewable.
2.	Prepare the mounting surface by attaching a board (typically plywood, 3/4" to 1" thick) to a wall stud. <i>Important! Mounting to a stud ensures stability. Using sheetrock anchors may not provide sufficient long-term stability.</i>
3.	Find exact positioning for the four wood screws by holding the NetVanta 950 IAD up to the plywood or mounting surface and making marks in each of the four holes located on the ears (attached to the back of the NetVanta 950 IAD chassis). Drill starter holes in the four locations (if desired).
4.	Install the four lug screws (included) at the marked positions. Be sure to leave 1/4" to 1/8" protruding to compensate for the thickness of the chassis sheet metal. Hang the chassis in place and tighten lug screws to lock the chassis firmly against the plywood or mounting surface.
5.	Proceed to the steps given in the <i>Installing Modules and Grounding Instructions</i> on page 30 and <i>Supplying Power to the Unit</i> on page 31.

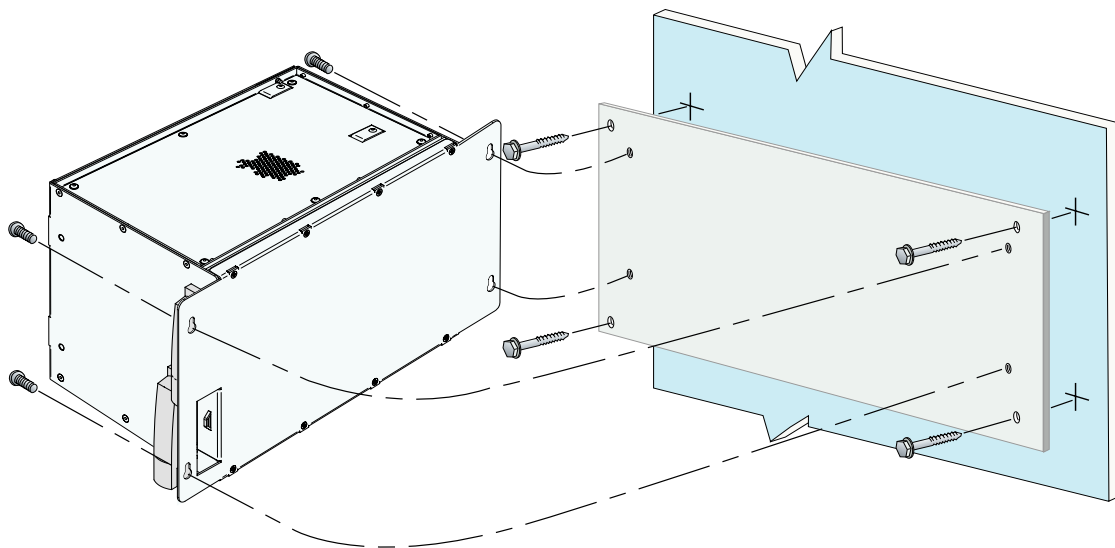



Figure 9. Wallmounting the NetVanta 950 IAD

Rackmounting NetVanta 950 IAD

The NetVanta 950 IAD can also be rackmounted in either a 19" or 23" equipment rack using an optional mounting kit. Rackmount kits can be purchased separately for installation in standard 19" rack (P/N 1200799L19) or a standard 23" rack (P/N 1200799L23). Follow these steps to mount the NetVanta 950 IAD into a rack:

 <p>CAUTION</p>	<p><i>Be careful not to upset the stability of the equipment mounting rack when installing this product.</i></p>
---	--

Instructions for Rackmounting NetVanta 950 IAD	
Step	Action
1.	Attach the rackmount ears to the NetVanta 950 IAD chassis (see Figure 10).
2.	Position the NetVanta 950 IAD in a stationary equipment rack. To allow proper grounding, scrape the paint from the rack around the mounting holes where the NetVanta 950 IAD will be positioned.
3.	Have someone else hold the unit in position as you install two mounting bolts through the unit's brackets and into the equipment rack using a Phillip's screwdriver.
4.	Proceed to the steps given in <i>Installing Modules</i> and <i>Grounding Instructions</i> on page 30 and <i>Supplying Power to the Unit</i> section on page 31.

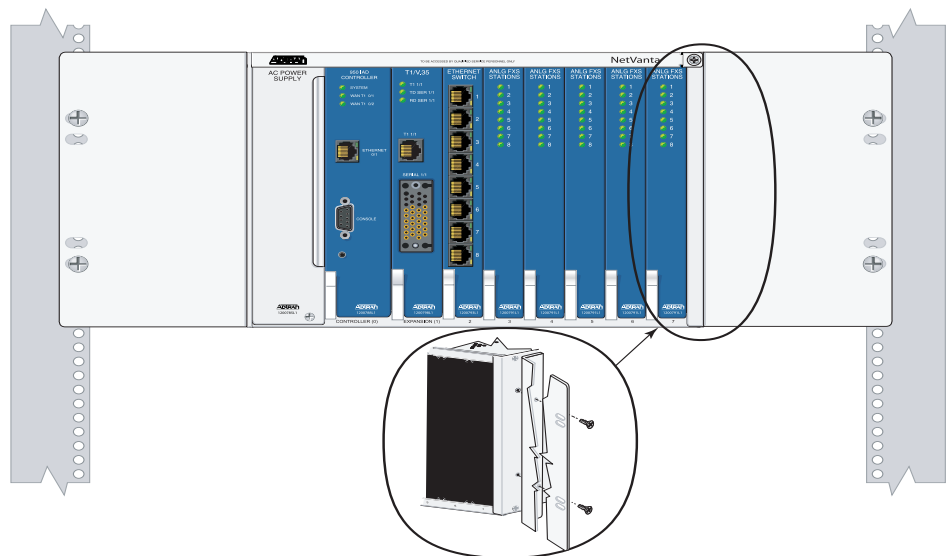

Figure 10. Rackmounting the NetVanta 950 IAD



The NetVanta 950 IAD system is intended to be installed, maintained, and serviced by qualified personnel only.

Installing Modules

The following table lists the installation steps for inserting modules into the NetVanta 950 IAD chassis.



Improper installation may result in damage to the modules.

Instructions for Installing Modules	
Step	Action
1.	Remove the locking bar from the front of the chassis. Remove the blank panel from slot if installed.
2.	Slide the module into the module slot until the module is firmly seated against the back of the chassis. Take care in verifying that the module is being installed in the correct module slot (controller and expansion slots are labeled on the front of the chassis and the access modules; the slots are 2-7).
	Note: Press firmly on the top and bottom of the faceplate to insure a proper fit.
3.	Replace the locking bar and secure it with a screwdriver. The locking bar must be attached at all times.
4.	Connect the cables to the associated device(s).
5.	Complete the installation of the system as specified in the Hardware Installation Guide.

Grounding Instructions

The following provides grounding instruction information for the Underwriters' Laboratory UL 60950 Standard for Safety of Information Technology Equipment Including Electrical Business Equipment, with revisions dated March 15, 2002.

A supplementary equipment grounding conductor shall be installed between the product or system and ground that is in addition to the equipment grounding conductor in the power supply cord.

The supplementary equipment grounding conductor shall not be smaller in size than the ungrounded branch-circuit supply conductors. The supplementary equipment grounding conductor shall be connected to the product at the terminal provided, and shall be connected to ground in a manner that will retain the ground connection when the product is unplugged from the receptacle. The connection to ground of the

supplementary equipment grounding conductor shall be in compliance with the rules for terminating bonding jumpers at Part K or Article 250 of the National Electrical Code, ANSI/NFPA 70. Termination of the supplementary equipment grounding conductor is permitted to be made to building steel, to a metal electrical raceway system, or to any grounded item that is permanently and reliably connected to the electrical service equipment ground.

The supplemental grounding conductor shall be connected to the equipment using a number 8 ring terminal and should be fastened to the grounding lug provided on the left side panel of the equipment. The ring terminal should be installed using the appropriate crimping tool (AMP P/N 59250 T-EAD Crimping Tool or equivalent).

Grounding for AC Power

The attachment-plug receptacles in the vicinity of the product or system are all to be of a grounding type, and the equipment grounding conductors serving these receptacles are to be connected to earth ground at the service equipment.

Grounding for DC Power (Optional Battery Backup)

The NetVanta 950 system is not DC powered. However, an optional DC battery backup system is available for the system (ADTRAN part number 1175044L1).

Supplying Power to the Unit

As shipped, the NetVanta 950 IAD is set to factory default conditions. After installing the chassis and any modules, the system is ready for power-up. To power-up the system, ensure that the unit is properly connected to an appropriate power source.

The NetVanta 950 IAD comes equipped with a detachable 6-foot power cord with a 3-prong plug for connecting to a grounded power receptacle. To power-up the unit, ensure that the power cord is securely attached to the unit (located on the left side panel) and connect the cord to the appropriate power supply.



- *Power to the NetVanta 950 IAD AC system must be from a grounded 90-120 VAC, 2A, 60 Hz source.*
- *Maximum recommended ambient operating temperature is 50°C.*

5. BATTERY BACKUP UNIT

The ADTRAN Battery Backup Unit is an optional device designed as a backup DC power supply for the NetVanta 950 IAD. The Battery Pack connects to the NetVanta 950 IAD through a 6-foot charge/discharge, 2-conductor wire with a keyed modular plug (included).

Features

Features of the Battery Pack, P/N 1175044L1, include the following:

- No-spill battery design
- Compact wallmount or rackmount box
- Double Battery Pack rackmounting available
- 7 Amp/hr batteries provide up to 8 hours of backup depending on load
- Modular plug provides quick and easy installation
- All mounting hardware included

Unpack and Inspect

WARNING

Removing the Battery Pack covers could allow batteries to fall out.

After unpacking the Battery Pack unit, inspect it for damage. If damage is noted, file a claim with the carrier; then contact ADTRAN Customer Service (see page 10).

WARNING

The Battery Pack weighs in excess of 30 pounds. Arrange for assistance when handling the Battery Pack for mounting.

Batteries are retained and pre-wired in the Battery Pack in a specific pattern. Battery position is maintained by foam spacers press-fitted against the housing walls. Removing batteries or disconnecting wires compromises correct reassembly and should not be attempted.

Safety Notices



When using the optional battery backup, the NetVanta 950 IAD must be operated with the Adtran Power Battery Charging Unit Power Supplies. The Battery Pack should only be used in specified Adtran applications.

This device complies with part 15 of the FCC rules. Operation is subject to the following two conditions:

- This device may not cause harmful interference, and
- This device must accept any interference that may cause undesired operation.

Changes or modifications not expressly approved by ADTRAN could void the user's authority to operate this equipment.

Installation of the Battery Pack

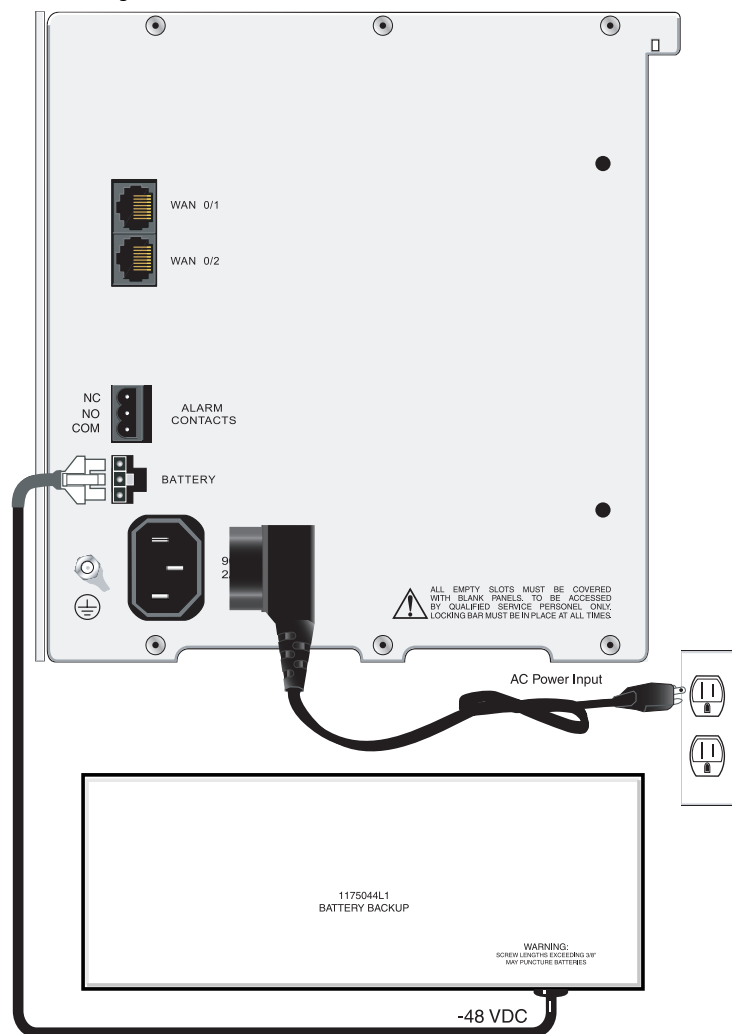

Figure 11. NetVanta 950 IAD Battery Pack Connections

There are three installation arrangements:

- Single Battery Pack, wallmount (standard)
- Single Battery Pack, rackmounted
- Double Battery Packs arranged back-to-back and rackmounted

The Battery Pack does not need to be opened for mounting.

Figure 12 shows the Battery Pack mounting dimensions.

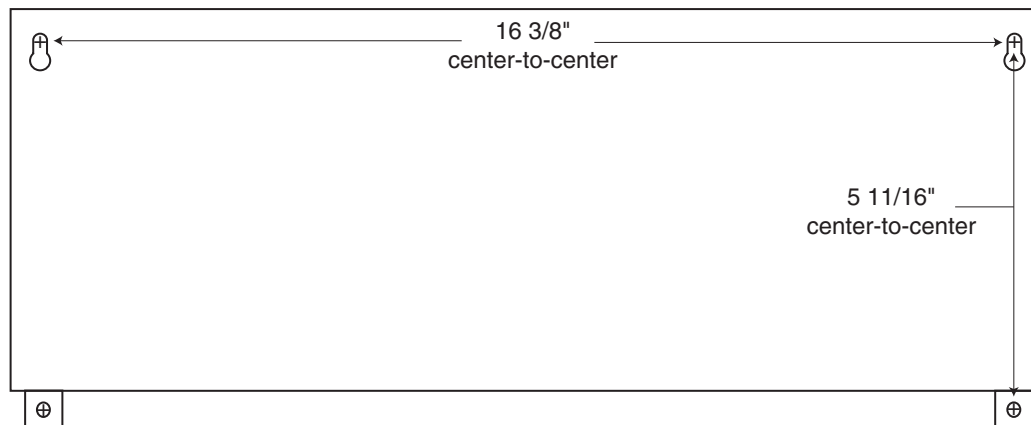

Figure 12. Battery Pack Mounting Dimensions

Wallmount Installation

For a wallmount installation, the Battery Pack installs on heavy plywood (3/4" minimum) using four #10 x 3/4" pan-head wood screws. Install the Battery Pack as follows:

1. Determine the preferred unit layout to ensure cable plugs reach their designated sockets.
2. Ensuring a plumb measurement, mark where the pilot holes are to be drilled according to the dimensions given in Figure 12 on page 34.
3. Drill all four pilot holes using a size 1/16" drill bit.
4. Screw the top two pan-head screws that fit the keyhole openings. Let the head of each screw protrude 1/16" from the plywood to engage the keyhole slot.

WARNING

Do not let the weight of the Battery Pack rest on the two keyhole screws. Maintain support until the upper two screws are fully inserted.

5. With an assistant, lift the Battery Pack and position to engage the screw heads. Allow the pack to slide down until the slot end rests against the screws.
6. Insert the two lower screws through the tabs and tighten securely.

- Use cable tie-downs as appropriate. The NetVanta 950 IAD battery connection from the Battery Pack should be directly connected to the Battery port on the left side of the chassis.

Maintenance

- The Battery Pack does not require routine maintenance for normal operation. The life expectancy of the battery pack is 3 to 5 years on standby use when used at room temperature.
- Excessive heat decreases battery power and life. Ideal ambient temperature for battery life and capacity is 20°C. Extreme low temperature also decreases battery capacity.
- Battery shelf life is extended in cooler temperatures.
- To order replacement batteries, reference the following part number: 1975044L1 (12 V replacement Battery).

ADTRAN is an environmental-friendly company. Therefore, we encourage the proper recycling and handling of the batteries. Federal and State laws prohibit the improper disposal of all lead acid batteries. The customer is responsible for the handling of their batteries from the day of purchase through their ultimate disposal. For more information on battery replacement and recycling, reference ADTRAN document number 60000120-36A on the ADTRAN OS System Documentation CD or online at www.adtran.com.

Specifications

Table 2 provides battery pack specifications.

Table 2. Battery Pack Specifications

Battery	
Part Number:	311212V02
Suppliers:	YUASA and Panasonic
Batteries:	7 Amp/hr per battery
Voltage:	-12 VDC per battery
Backup Time:	Up to 8 hours
Wire Gauge:	18 AWG
Environmental	
Operating Temperatures:	Charge: -15° to 50° C Discharge: -20° to 60° C
Preferred:	20°
Physical	
Dimensions:	17" W x 6.5" H x 3.5" D
Weight:	30 lb.

APPENDIX A. PIN ASSIGNMENTS

Chassis Pinouts

Table A-1. WAN 0/1, 0/2 Connector Pinout

Pin	Name	Description
1	R1	Receive data from the network—RING 1
2	T1	Receive data from the network—TIP 1
3	—	UNUSED
4	R	Transmit data toward the network—RING
5	T	Transmit data toward the network—TIP
6-8	—	UNUSED

Table A-2. Alarm Contacts

Pin	Description
1	Normally Closed
2	Normally Opened
3	Common

Controller Pinouts

Table A-3. 10/100BaseT Ethernet Port Pinout

Pin	Name	Description
1	TX1	Transmit Positive
2	TX2	Transmit Negative
3	RX1	Receive Positive
4,5	—	UNUSED
6	RX2	Receive Negative
7,8	—	UNUSED

Table A-4. Console Port (DCE) Pinout

Pin	Name	Description
1	DCD	Data Carrier Detect (output)
2	RD	Receive Data (output)
3	TD	Transmit Data (input)
4	DTR	Data Terminal Ready (input)
5	SG	Signal Ground
6	DSR	Data Set Ready (output)
7	RTS	Request to Send (input)
8	CTS	Clear to Send (output)
9	RI	Ring Indicate (output)



Connection directly to an external modem requires a cross-over cable.

Module Pinouts

Expansion Module Interfaces

Table A-5. T1 Connector Pinout

Pin	Name	Description
1	R1	Receive data from the network—RING 1
2	T1	Receive data from the network—TIP 1
3	—	UNUSED
4	R	Transmit data toward the network—RING
5	T	Transmit data toward the network—TIP
6-8	—	UNUSED

Table A-6. V.35 Connector Pinout

Pin	CCITT/V.24	Description
A	101	Protective Ground (PG)
B	102	Signal Ground (SG)
C	105	Request to Send (RTS) from DTE
D	106	Clear to Send (CTS) to DTE
E	107	Data Set Ready (DSR) to DTE
F	109	Received Line Signal Detector (DCD) to DTE
H	108/2	Data Terminal Ready (DTR) from DTE
J	125	Ring Indicator (RI) to DTE
R	104	Received Data (RD-A) to DTE
T	104	Received Data (RD-B) to DTE
V	115	RX Clock (RC-A) to DTE
X	115	RX Clock (RC-B) to DTE
P	103	Transmitted Data (TD-A) from DTE
S	103	Transmitted Data (TD-B) from DTE
Y	114	TX Clock (TC-A) to DTE
AA	114	TX Clock (TC-B) to DTE
U	113	External TX Clock (ETC-A) from DTE
W	113	External TX Clock (ETC-B) from DTE
NN	142	Test Mode (TM) to DTE

Ethernet Switch Module Pinout**Table A-7. 10/100BaseT Ethernet Port Pinout**

Pin	Name	Description
1	TX1	Transmit Positive
2	TX2	Transmit Negative
3	RX1	Receive Positive
4,5	—	UNUSED
6	RX2	Receive Negative
7,8	—	UNUSED

Voice Module Pinout**Table A-8. Voice Interface Pinout (Slots 2 - 4)**

Pin	50-pin Amphenol Connector	Description
1	Slots 2-4	Slot 2/1 - Ring
2	Slots 2-4	Slot 2/2 - Ring
3	Slots 2-4	Slot 2/3 - Ring
4	Slots 2-4	Slot 2/4 - Ring
5	Slots 2-4	Slot 2/5 - Ring
6	Slots 2-4	Slot 2/6 - Ring
7	Slots 2-4	Slot 2/7 - Ring
8	Slots 2-4	Slot 2/8 - Ring
9	Slots 2-4	Slot 3/1 - Ring
10	Slots 2-4	Slot 3/2 - Ring
11	Slots 2-4	Slot 3/3 - Ring
12	Slots 2-4	Slot 3/4 - Ring
13	Slots 2-4	Slot 3/5 - Ring
14	Slots 2-4	Slot 3/6 - Ring
15	Slots 2-4	Slot 3/7 - Ring
16	Slots 2-4	Slot 3/8 - Ring
17	Slots 2-4	Slot 4/1 - Ring
18	Slots 2-4	Slot 4/2 - Ring
19	Slots 2-4	Slot 4/3 - Ring
20	Slots 2-4	Slot 4/4 - Ring
21	Slots 2-4	Slot 4/5 - Ring
22	Slots 2-4	Slot 4/6 - Ring
23	Slots 2-4	Slot 4/7 - Ring
24	Slots 2-4	Slot 4/8 - Ring
25	Slots 2-4	Reserved - Future
26	Slots 2-4	Slot 2/1 - Tip
27	Slots 2-4	Slot 2/2 - Tip
28	Slots 2-4	Slot 2/3 - Tip
29	Slots 2-4	Slot 2/4 - Tip
30	Slots 2-4	Slot 2/5 - Tip
31	Slots 2-4	Slot 2/6 - Tip
32	Slots 2-4	Slot 2/7 - Tip
33	Slots 2-4	Slot 2/8 - Tip
34	Slots 2-4	Slot 3/1 - Tip

Table A-8. Voice Interface Pinout (Slots 2 - 4) (Continued)

Pin	50-pin Amphenol Connector	Description
35	Slots 2-4	Slot 3/2 - Tip
36	Slots 2-4	Slot 3/3 - Tip
37	Slots 2-4	Slot 3/4 - Tip
38	Slots 2-4	Slot 3/5 - Tip
39	Slots 2-4	Slot 3/6 - Tip
40	Slots 2-4	Slot 3/7 - Tip
41	Slots 2-4	Slot 3/8 - Tip
42	Slots 2-4	Slot 4/1 - Tip
43	Slots 2-4	Slot 4/2 - Tip
44	Slots 2-4	Slot 4/3 - Tip
45	Slots 2-4	Slot 4/4 - Tip
46	Slots 2-4	Slot 4/5 - Tip
47	Slots 2-4	Slot 4/6 - Tip
48	Slots 2-4	Slot 4/7 - Tip
49	Slots 2-4	Slot 4/8 - Tip
50	Slots 2-4	Reserved - Future

Table A-9. Voice Interface Pinout (Slots 5 - 7)

Pin	50-pin Amphenol Connector	Description
1	Slots 5-7	Slot 5/1 - Ring
2	Slots 5-7	Slot 5/2 - Ring
3	Slots 5-7	Slot 5/3 - Ring
4	Slots 5-7	Slot 5/4 - Ring
5	Slots 5-7	Slot 5/5 - Ring
6	Slots 5-7	Slot 5/6 - Ring
7	Slots 5-7	Slot 5/7 - Ring
8	Slots 5-7	Slot 5/8 - Ring
9	Slots 5-7	Slot 6/1 - Ring
10	Slots 5-7	Slot 6/2 - Ring
11	Slots 5-7	Slot 6/3 - Ring
12	Slots 5-7	Slot 6/4 - Ring
13	Slots 5-7	Slot 6/5 - Ring
14	Slots 5-7	Slot 6/6 - Ring
15	Slots 5-7	Slot 6/7 - Ring

Table A-9. Voice Interface Pinout (Slots 5 - 7) (Continued)

Pin	50-pin Amphenol Connector	Description
16	Slots 5-7	Slot 6/8 - Ring
17	Slots 5-7	Slot 7/1 - Ring
18	Slots 5-7	Slot 7/2 - Ring
19	Slots 5-7	Slot 7/3 - Ring
20	Slots 5-7	Slot 7/4 - Ring
21	Slots 5-7	Slot 7/5 - Ring
22	Slots 5-7	Slot 7/6 - Ring
23	Slots 5-7	Slot 7/7 - Ring
24	Slots 5-7	Slot 7/8 - Ring
25	Slots 5-7	Reserved - Future
26	Slots 5-7	Slot 5/1 - Tip
27	Slots 5-7	Slot 5/2 - Tip
28	Slots 5-7	Slot 5/3 - Tip
29	Slots 5-7	Slot 5/4 - Tip
30	Slots 5-7	Slot 5/5 - Tip
31	Slots 5-7	Slot 5/6 - Tip
32	Slots 5-7	Slot 5/7 - Tip
33	Slots 5-7	Slot 5/8 - Tip
34	Slots 5-7	Slot 6/1 - Tip
35	Slots 5-7	Slot 6/2 - Tip
36	Slots 5-7	Slot 6/3 - Tip
37	Slots 5-7	Slot 6/4 - Tip
38	Slots 5-7	Slot 6/5 - Tip
39	Slots 5-7	Slot 6/6 - Tip
40	Slots 5-7	Slot 6/7 - Tip
41	Slots 5-7	Slot 6/8 - Tip
42	Slots 5-7	Slot 7/1 - Tip
43	Slots 5-7	Slot 7/2 - Tip
44	Slots 5-7	Slot 7/3 - Tip
45	Slots 5-7	Slot 7/4 - Tip
46	Slots 5-7	Slot 7/5 - Tip
47	Slots 5-7	Slot 7/6 - Tip
48	Slots 5-7	Slot 7/7 - Tip
49	Slots 5-7	Slot 7/8 - Tip
50	Slots 5-7	Reserved - Future

APPENDIX B. ADTRAN AOS SUPPORTED MIBS

ADTRAN AOS platforms support the MIBs listed in Table 1. For the most up-to-date MIB list, please visit our website at www.adtran.com.

Table B-1. MIBs Supported in the AOS

Name	RFC	Description	Notes
DS1-MIB	2495	Describes DS1, E1, DS2, and E2 interfaces objects.	1
Ether-like-MIB	2665	Describes generic objects for Ethernet-like network interfaces.	2
FRAME-RELAY-DTE-MIB	2115	Describes the use of a Frame Relay interface by a DTE.	3
IF-MIB	2863	Describes generic objects for network interface sub-layers.	4
MAU-MIB	2668	Management information for 802.3 Media Access Units (MAU or transceiver).	5
SNMPv2-MIB	1907	The MIB module for SNMPv2 entities.	6
IP-MIB	2011	Describes IP and ICMP implementations, excluding the management of IP routes.	7
IP-FORWARD-MIB	2096	Describes CIDR multi-path IP Routes.	8
ADTRAN-AOS-VOICE-MIB		ADTRAN enterprise MIB, for general configuration of various voice interface types.	
ADTRAN-AOS-MUX-MIB		ADTRAN enterprise MIB, for the management of AOS products supporting TDM groups and/or cross-connects.	

Standard MIBs are supported with the following exclusions. These exclusions were agreed upon at the time the MIBs were implemented and represent objects that have been made obsolete, deprecated, or are objects we simply do not support at this time.

Table B-2. Notes Regarding MIB Exclusions

Note 1: DS1 exclusions
dsx1FarEndCurrentTable dsx1FarEndIntervalTable dsx1FarEndTotalTable dsx1FracTable
Note 2: EtherLike exclusions
dot3StatsTable <ul style="list-style-type: none"> • <i>dot3StatsSQETestErrors</i> • <i>dot3StatsEtherChipSet</i> dot3CoIITable dot3ControlTable <ul style="list-style-type: none"> • <i>dot3ControlInUnknownOpcodes</i> dot3PauseTable <ul style="list-style-type: none"> • <i>dot3InPauseFrames</i> • <i>dot3OutPauseFrames</i>
Note 3: FRAME-RELAY-DTE exclusions
frDlcmiTable <ul style="list-style-type: none"> • <i>frDlcmiAddress</i> • <i>frDlcmiAddressLen</i> • <i>frDlcmiMulticast</i> frCircuitTable <ul style="list-style-type: none"> • <i>frCircuitExcessBurst</i> (set not allowed) • <i>frCircuitLogicalIfIndex</i> (set not allowed) • <i>frCircuitRowStatus</i> frErrTable <i>frTrapState</i> <i>frTrapMaxRate</i>
Note 4: IF exclusions
IfTable <ul style="list-style-type: none"> • <i>ifInNUcastPkts</i> • <i>ifOutNUcastPkts</i> • <i>ifOutQLen</i> • <i>ifSpecific</i> ifXTable <ul style="list-style-type: none"> • <i>ifHCInUcastPkts</i> • <i>ifHCInMulticastPkts</i> • <i>ifHCInBroadcastPkts</i> • <i>ifHCOUcastPkts</i> • <i>ifHCOMulticastPkts</i> • <i>ifHCOBroadcastPkts</i> ifStackTable ifTestTable IfRcvAddressTable
Note 5: MAU exclusions
rpMauTable rpJackTable broadMauBasicTable

Table B-2. Notes Regarding MIB Exclusions (Continued)

Note 6: SNMPv2 exclusions*sysORLastChange***sysORTable***snmpOutPkts**snmpInTooBigs**snmpInNoSuchNames**snmpInBadValues**snmpInReadOnlys**snmpInGenErrs**snmpInTotalReqVars**snmpInTotalSetVars**snmpInGetRequests**snmpInGetNexts**snmpInSetRequests**snmpInGetResponses**snmpInTraps**snmpOutTooBigs**snmpOutNoSuchNames**snmpOutBadValues**snmpOutGenErrs**snmpOutGetRequests**snmpOutGetNexts**snmpOutSetRequests**snmpOutGetResponses**snmpOutTraps**snmpTrapOID**snmpTrapEnterprise***Note 7: IP exclusions***ipForwarding**ipDefaultTTL**ipInReceives**ipInHdrErrors**ipInAddrErrors**ipForwDatagrams**ipInUnknownProtos**ipInDiscards**ipInDelivers**ipOutRequests**ipOutDiscards*

Table B-2. Notes Regarding MIB Exclusions (Continued)

Note 7: IP exclusions (Continued)
<i>ipOutNoRoutes</i>
<i>ipReasmTimeout</i>
<i>ipReasmReqds</i>
<i>ipReasmOKs</i>
<i>ipReasmFails</i>
<i>ipFragOKs</i>
<i>ipFragFails</i>
<i>ipFragCreates</i>
ipNetToMediaTable
Note 8: IP-FORWARD exclusions
<i>ipForwardNumber</i>
ipForwardTable
<i>ipCidrRouteNumber</i>

Table B-3. Traps Supported in the AOS

Name	OID
Cold Start	1.3.6.1.6.3.1.1.5.1
Warm Start	1.3.6.1.6.3.1.1.5.2
Link Down	1.3.6.1.6.3.1.1.5.3
Link Up	1.3.6.1.6.3.1.1.5.4
Authentication Failure	1.3.6.1.6.3.1.1.5.5

Index

Numerics

10/100BaseT Ethernet
 interface 20
10/100BaseT Ethernet interface 20
10/100BaseT Ethernet pinout 37, 39
10BaseT/100BaseTX (RJ-48C) interfaces 26
50-pin amphenol connectors 20

A

AC power 31
alarm contacts 20, 37
auto MDI/MDIX 26

B

battery backup connection 20
battery backup unit 32

C

compliance information 9
console port pinout 38
contents of shipment 16
controller pinouts 37
customer service, product support information, and training 10

D

DC power 31
DSX-1 interface 38

E

Ethernet 18

F

FCC regulations 7
features 15
front panel 17
front panel LEDs 18

G

grounding instructions 30

I

impedance 25
installation, wallmount 34
installing modules 30
instructions for rackmounting NetVanta 950 IAD 29

instructions for wallmounting NetVanta 950 IAD 28

L

LEDs 18

M

maintenance 35
MIBs 43
module installation 30
modules 22

O

octal Ethernet switch access module 26
octal FXS access module 25

P

panel layout 19
pinout
 DSX-1 interface 38
Pinouts
 10/100BaseT 37, 39
 WAN/T1 37
pinouts
 console port 38
 T1 38
 WAN/T1 37
port tests 25
power 31
power supply 31
product registration 10

R

rackmounting 29
repair and return 10

S

safety instructions 3
shipping contents 16
specifications 35
supplying power 31

T

T1 20
T1 interface 24
T1/V.35 expansion module 24
training 11

U

unit installation 27

unpacking and inspecting the system 16

V

V.35 connector pinout 39

V.35 interface 24

voice connections 20

voice interface pinout 40

W

wall mount installation 34

WAN interfaces 20

WAN LED 18

WAN/T1 interface
pinout 37